



# What is Trustworthiness?

Trustworthiness is the degree of confidence one has that the system performs as expected.

Characteristics include:

- safety,
- security,
- privacy,
- reliability and
- resilience

in the face of environmental disturbances, human errors, system faults and attacks.

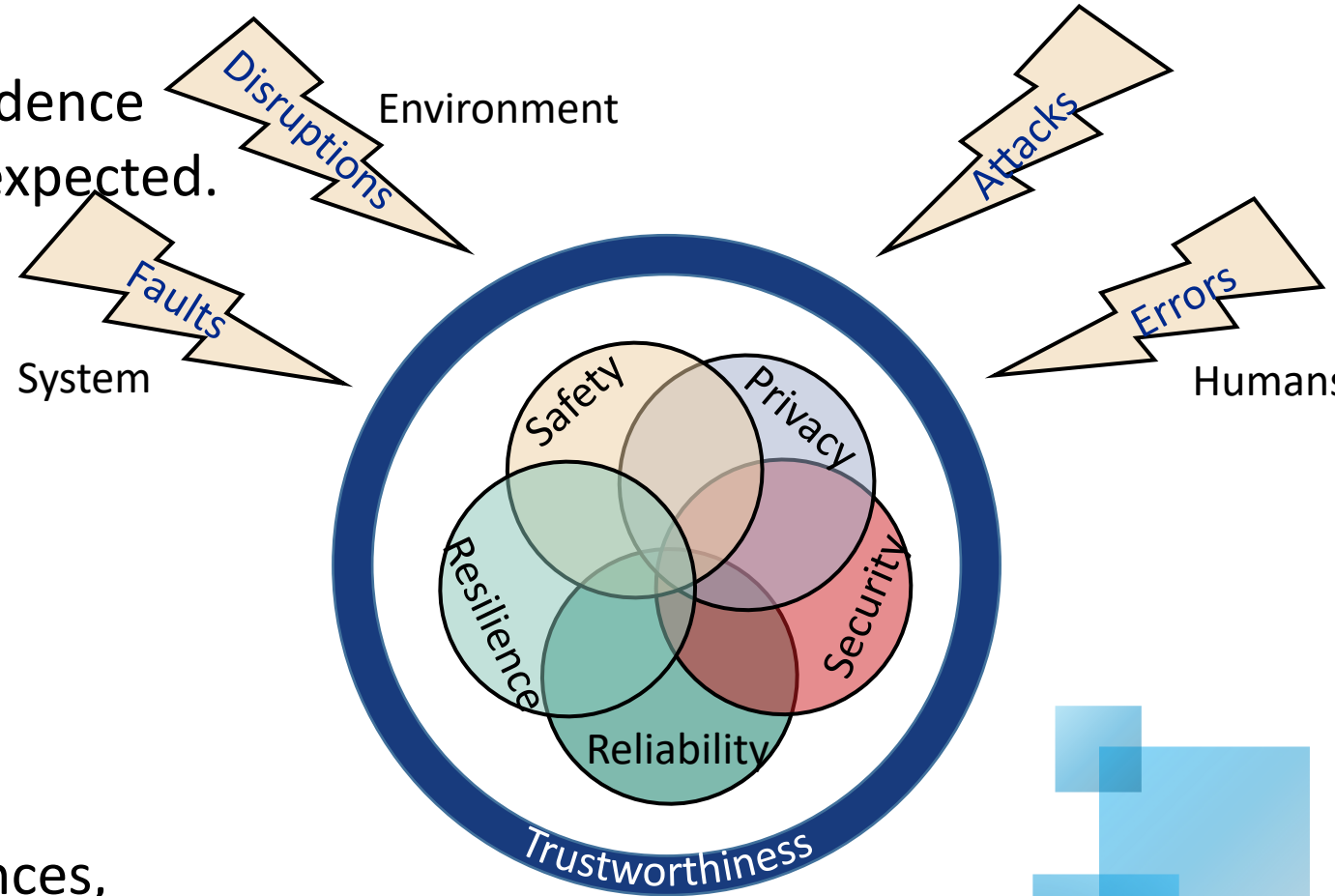

# Why do you care?

In a Jeep Cherokee:

1. Easy to guess password
2. Checksum not used
3. Spoofed speed messages

You can take over the vehicle.

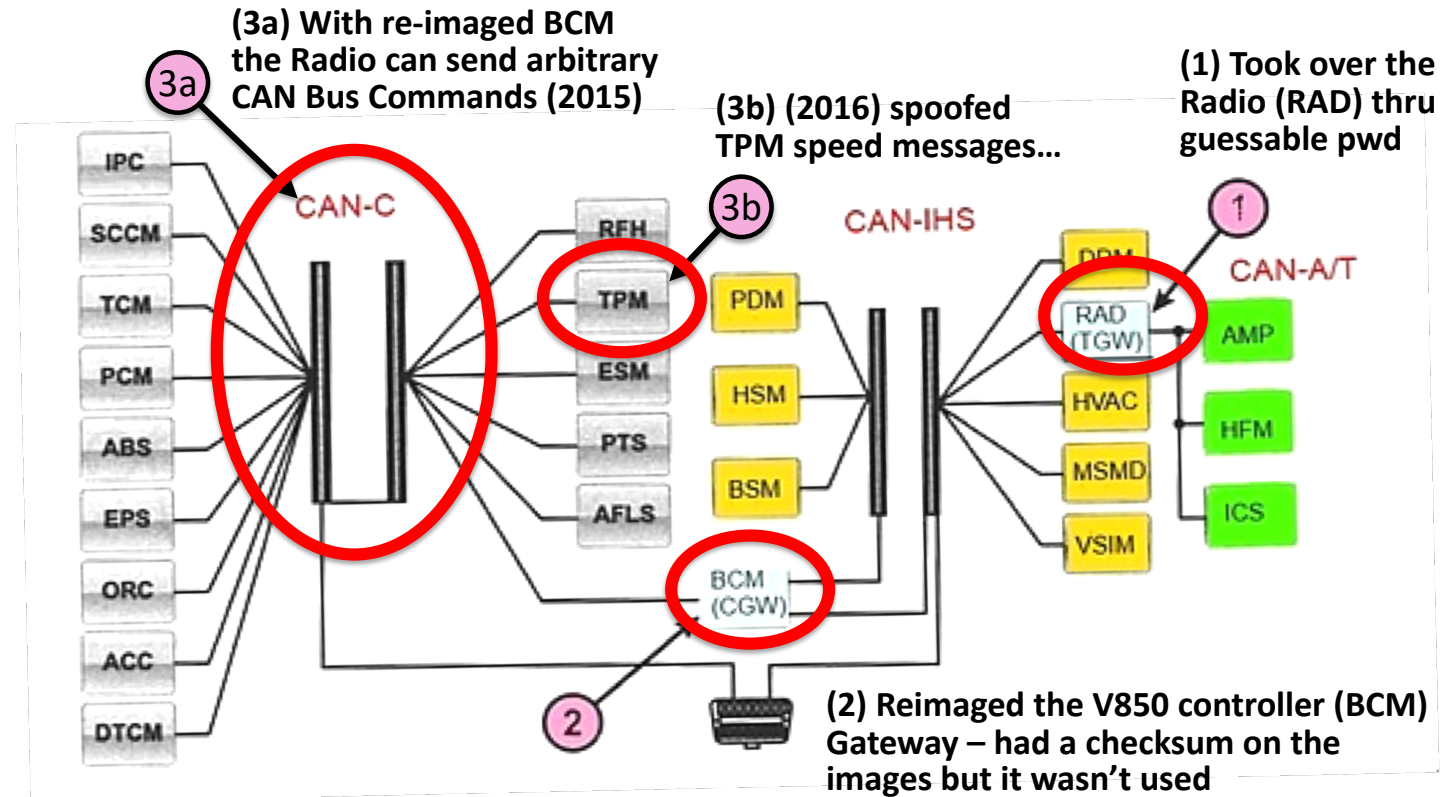

# Collaborative Computing Enterprises

In industrial systems, the major “collaboration” is between IT and OT.

They have different

- languages
- concerns
- time horizons
- emphases

The office floor and the shop floor are entirely different

How can they collaborate effectively?





# Languages

What does “security” mean?

- barbed wire? security guards?
- firewalls? worms?

What about “safety”?

- protection from physical harm? culture?
- synonym for “security”? coding practices?

*Expect not to have the same understanding.*



# Concerns

What concerns you daily?

- throughput/productivity?
- safety?
- physical intrusion?
- vulnerability to attack?
- crashes?
- meeting real-time constraints?



# Time Horizons



How much does it cost to update your system?  
How frequently? How is it authorized?

- Lots!
- Annually, unless we can avoid it!
- From the top, during scheduled shutdowns.
  
- Cost? What do you mean?
- Happened multiple times this month.
- Authorized? It's automatic





# Emphases: Trustworthiness in Information Technology

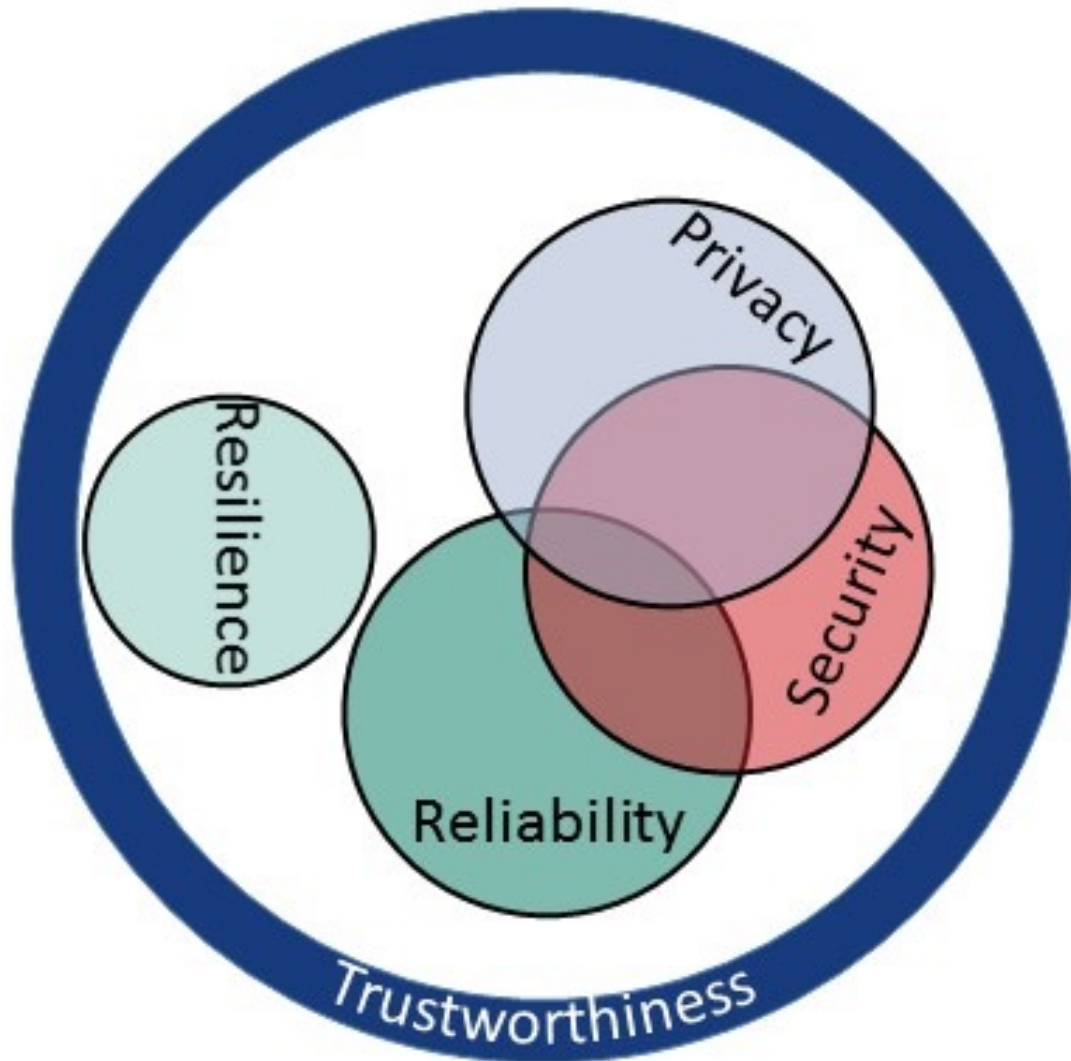

IT Security specialists focus on:

- Security first,
- then Privacy and
- Reliability.

Resilience is “interesting” for financial transactions.



# Emphases: Trustworthiness in Operational Technology

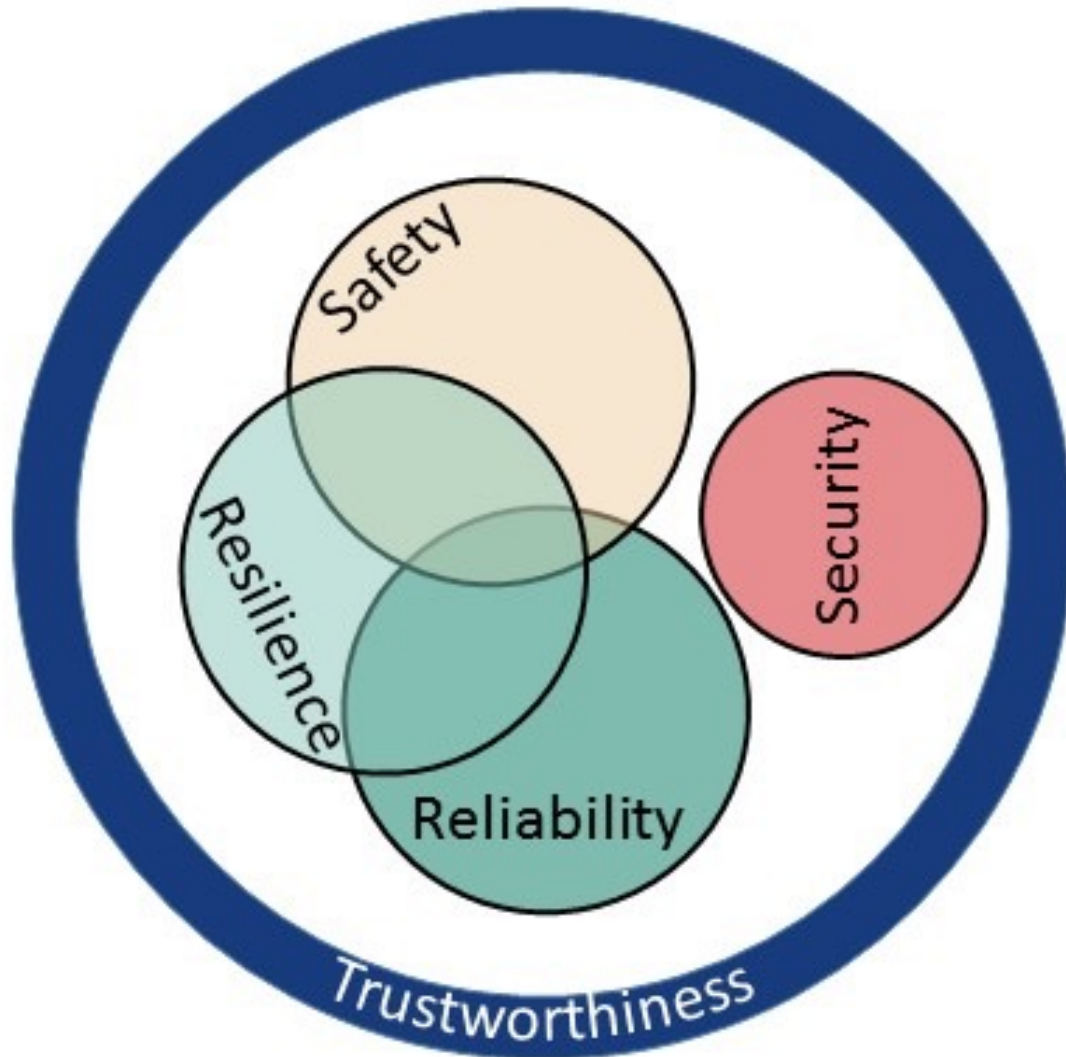

Operational Technology experts focus on:

- Safety,
- Resilience and
- Reliability

Security is “interesting” now that control systems are connected to the Wide Wide World.



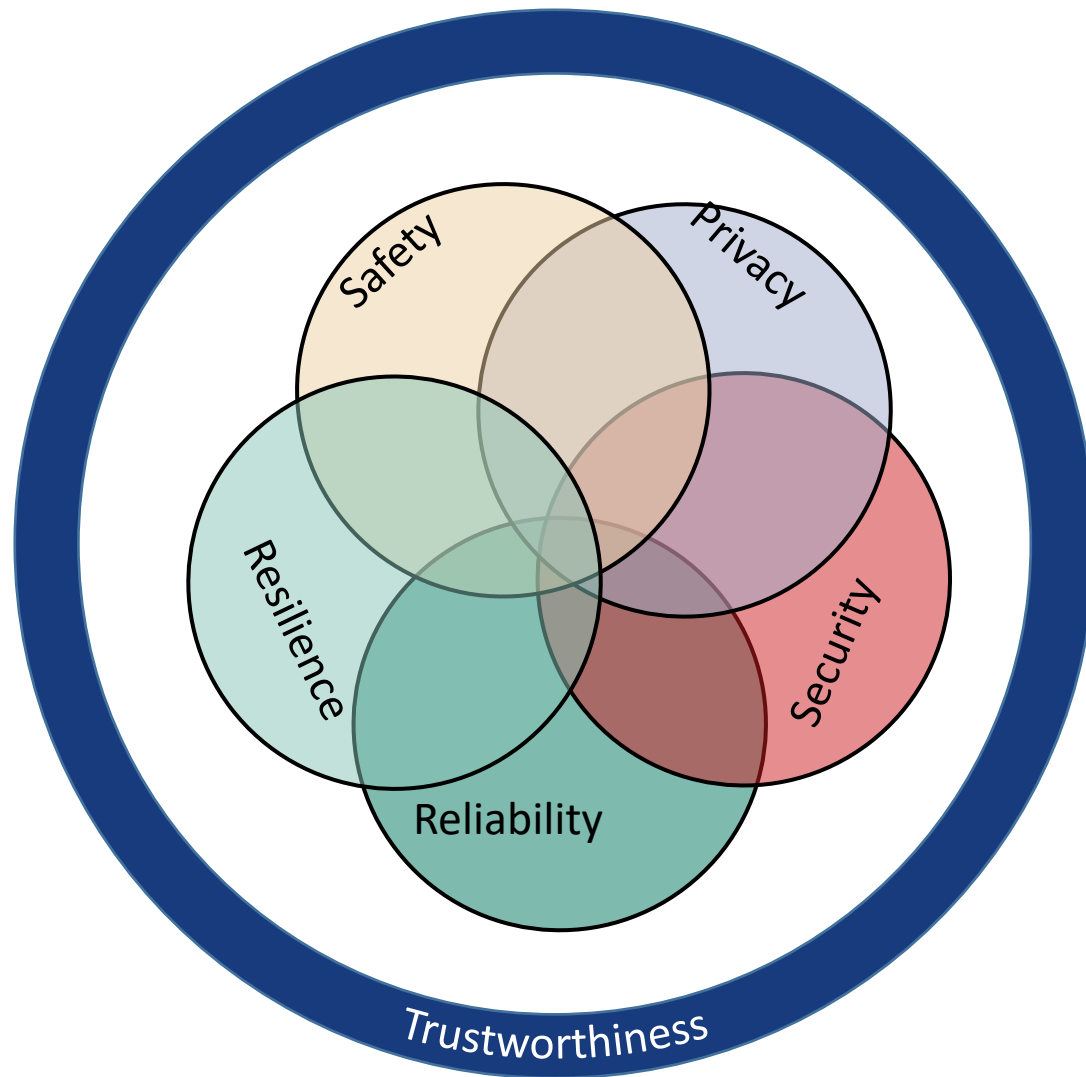

Trustworthiness is a combination of these five elements:

- Safety
- Security
- Resilience
- Reliability
- Privacy

(not only security and privacy).

*These must be reconciled.*



# Permeation of Trust

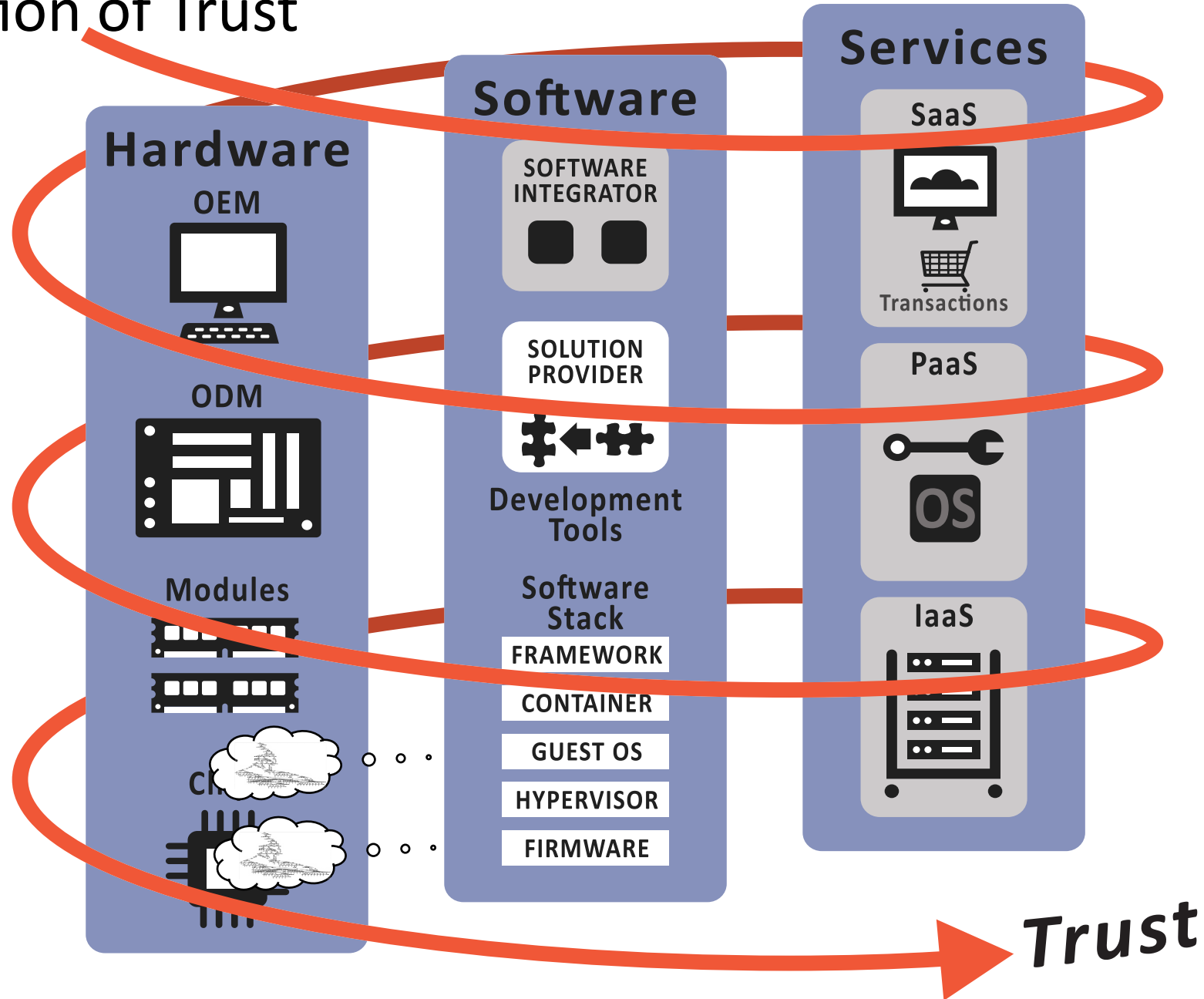



# Trust and Assurance

For trust, we need *assurance*.



# Perspectives on Assurance

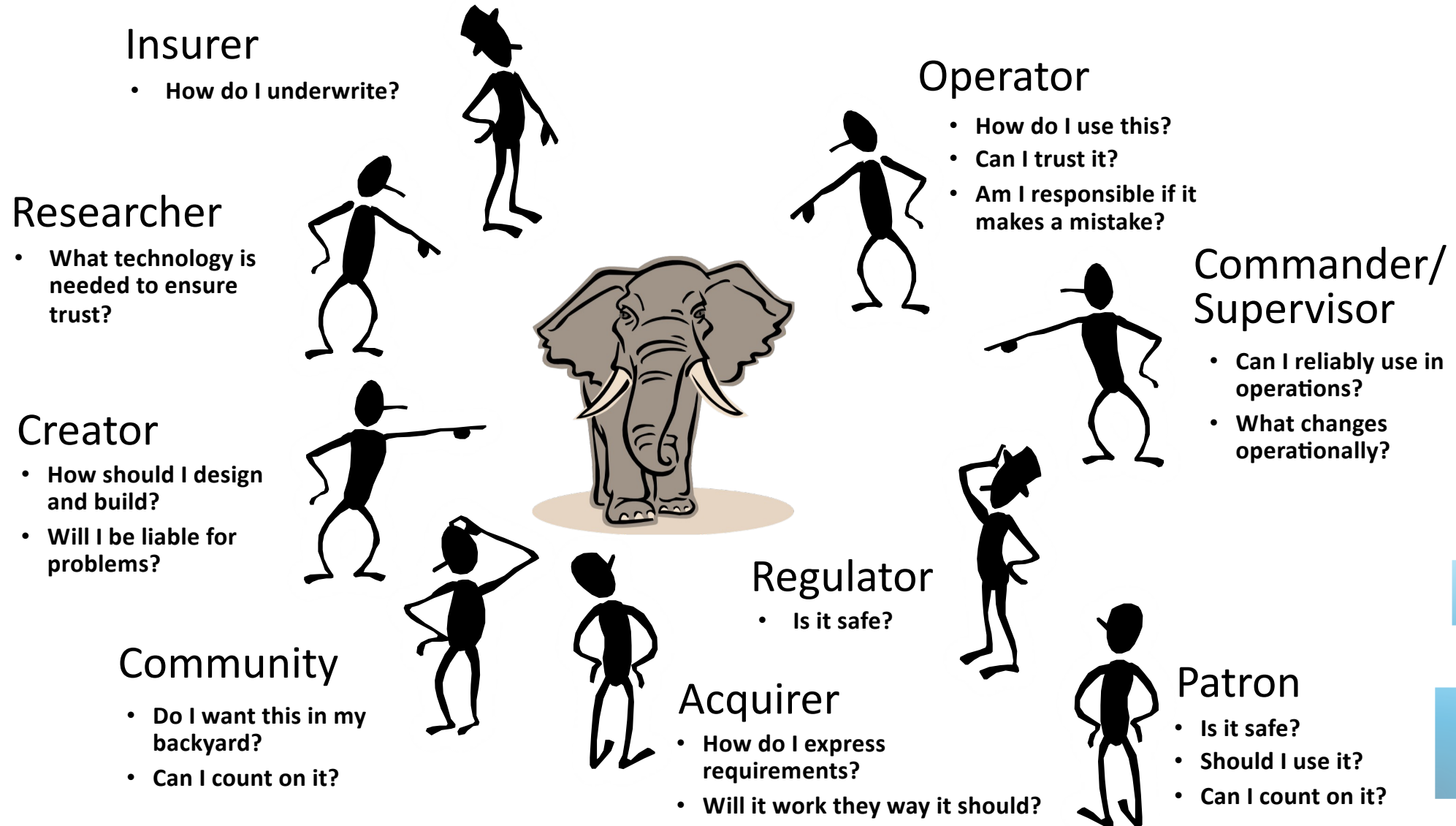

# Definition of Assurance Case

A documented body of evidence that provides a convincing and valid argument that a specified set of critical claims regarding a system's properties are adequately justified for a given application in a given environment.

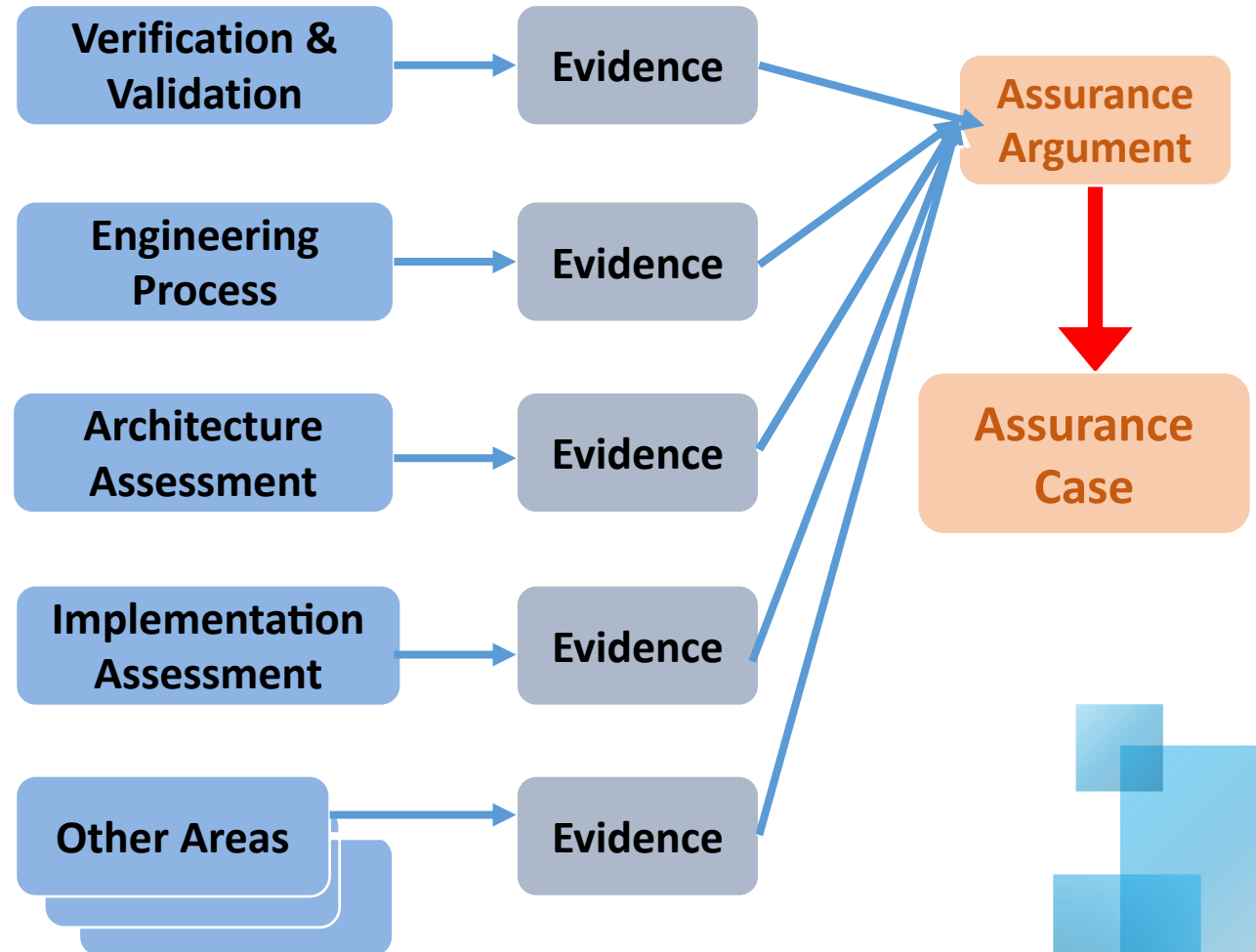

# And Assurance

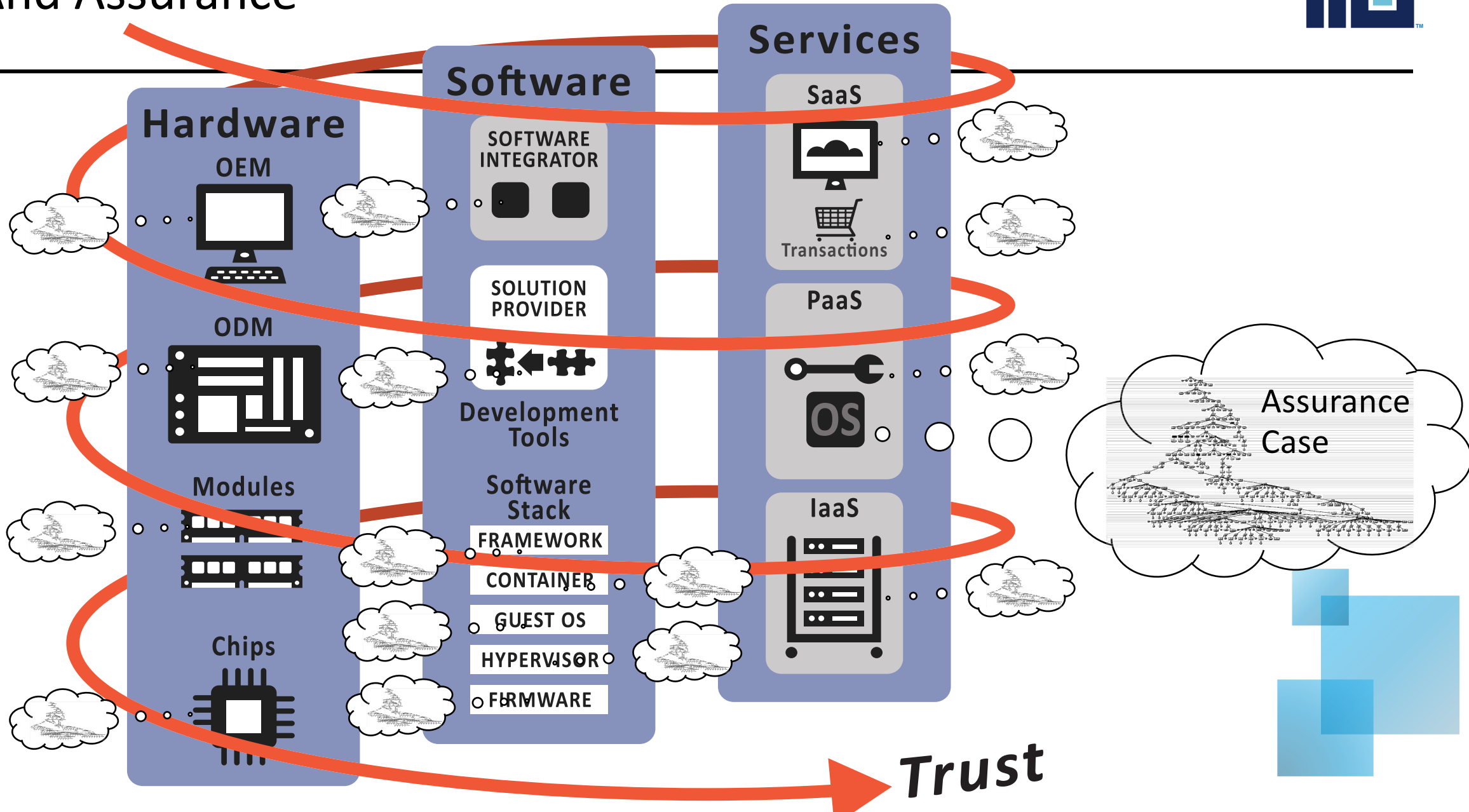

# Key Messages

---



1. Trust does not happen on its own. It must be requested
2. Owners need to drive trust requirements top down
3. Trust is only achieved when capabilities that meet trust requirement are delivered and assured by the recipient
4. All players in the supply chain have a role and responsibility in delivering trust
5. Trust must exist in the components of the system, their integration and their use
6. Trust that must exist among all the vendors and suppliers that contribute to the delivery of the system and its operational use
7. Trust requires assurance





# But how?

---



- Principle 1: Trustworthiness characteristics must be considered holistically.
- Principle 2: Understanding context is necessary for making Trustworthiness tradeoffs.
- Principle 3: Organizational consistency over time enables reputation and trust.
- Principle 4: Accountability is an essential underlying foundation of trustworthiness.
- Principle 5: A culture of trustworthiness is essential to achieving trustworthiness.
- Principle 6: Assurance based on evidence is essential to establish trustworthiness.
- Principle 7: Software trustworthiness must be managed throughout the entire software lifecycle.
- Principle 8: Implementing trustworthiness means implementing trustworthiness methods
- Principle 9: Maintaining change and audit records is necessary for trustworthiness.
- Principle 10: A trustworthiness framework must enable timely business decisions.
- Principle 11: Assurance requires a systems viewpoint with evidence of multiple factors.

# Principle 1

Trustworthiness characteristics must be considered holistically.

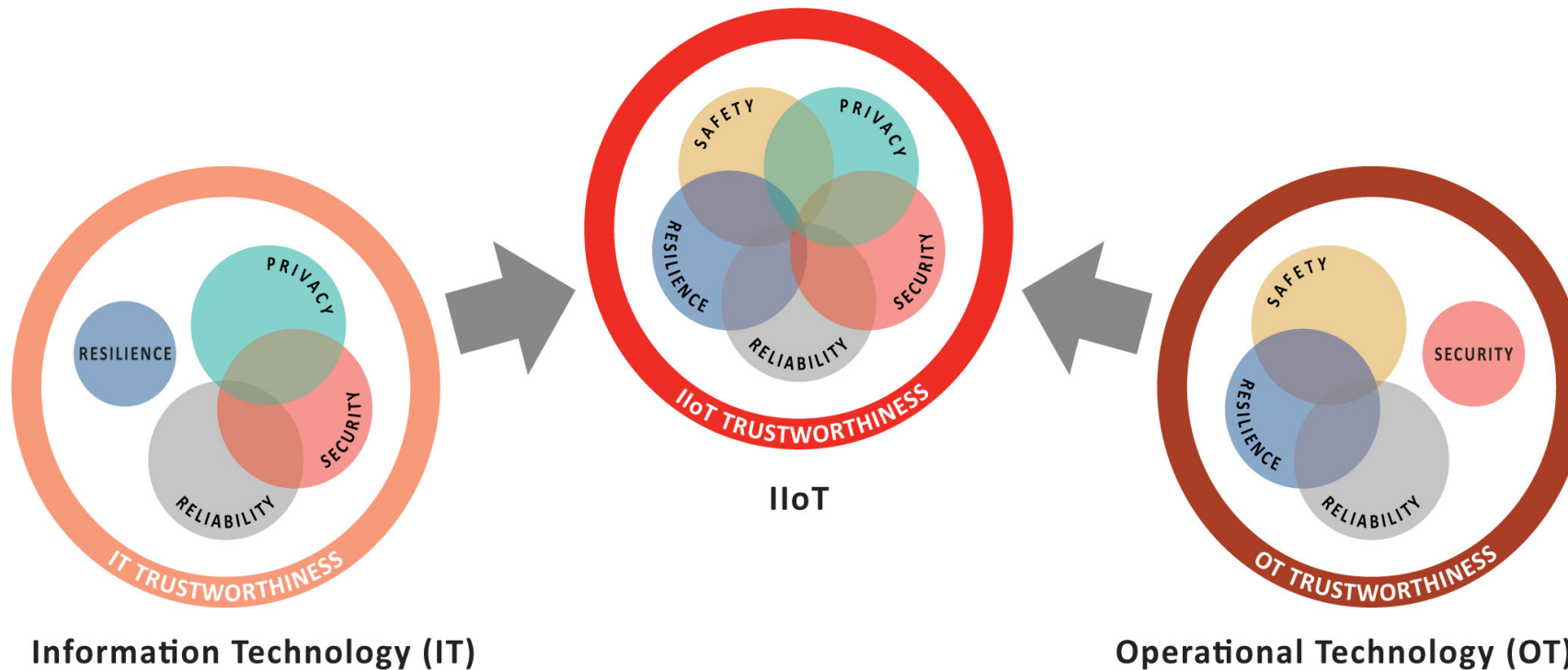

Varying weights are given to each characteristic by each community.





# Principles 3 & 4

---



Organizational consistency over time enables reputation and trust.

Accountability is an essential underlying foundation of trustworthiness.

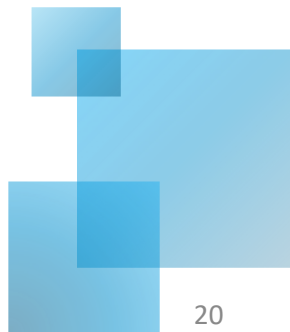

# Principle 5

A culture of trustworthiness is essential to achieving trustworthiness.

If the organization does not support trustworthiness, it won't happen:

- separate teams for development and monitoring
- free from undue influence from budget or management

This is especially true in software.



# Principle 6



Assurance based on evidence is essential to establish trustworthiness.

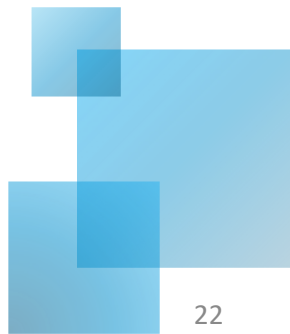
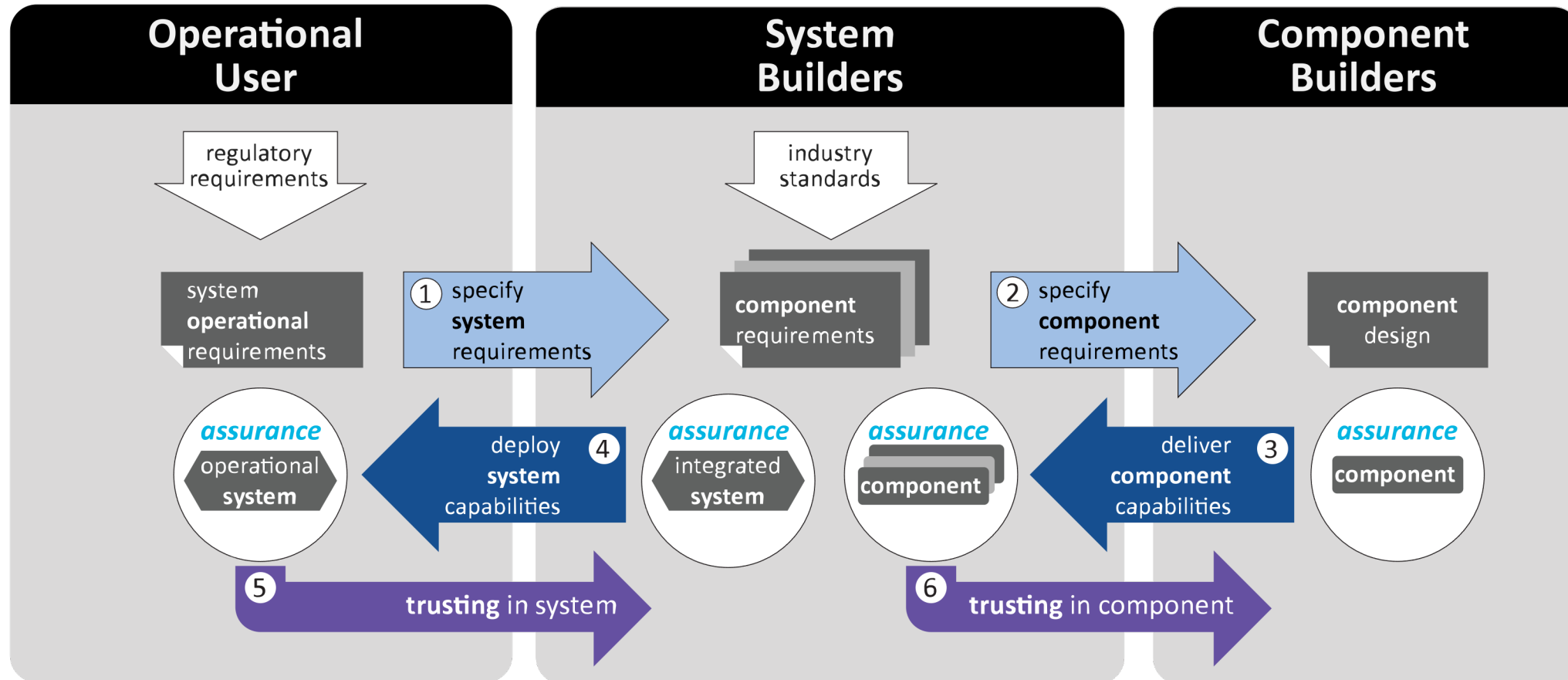

# Principle 7

Software trustworthiness must be managed through the lifecycle.

Techniques include:

- Software composition must be managed:
  - software bill of materials,
  - and how it was built.
- Software protection: software executables must be resistant to modification and hinder discovery of the intellectual property.

throughout the lifecycle: including creation, operation, updating and decommissioning.





# Principle 8



Implementing trustworthiness means implementing *trustworthiness methods*.

Examples:

- *Fire extinguisher*: a tool and a safety method
- CO2 fire suppression system: a tool and a resilience method.
- *Network firewall*: a tool and a security method.
- *Melt-resistant steel*: technology and a resilience method.
- *Windmill restart*: operational procedure for airplanes during an engine flameout and a resilience method.
- *Encryption of all social security numbers on servers*: management directive and a privacy method.



# Principle 9



Maintaining change and audit records is necessary for trustworthiness.

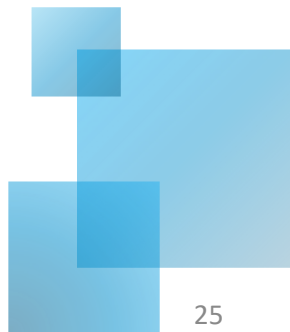
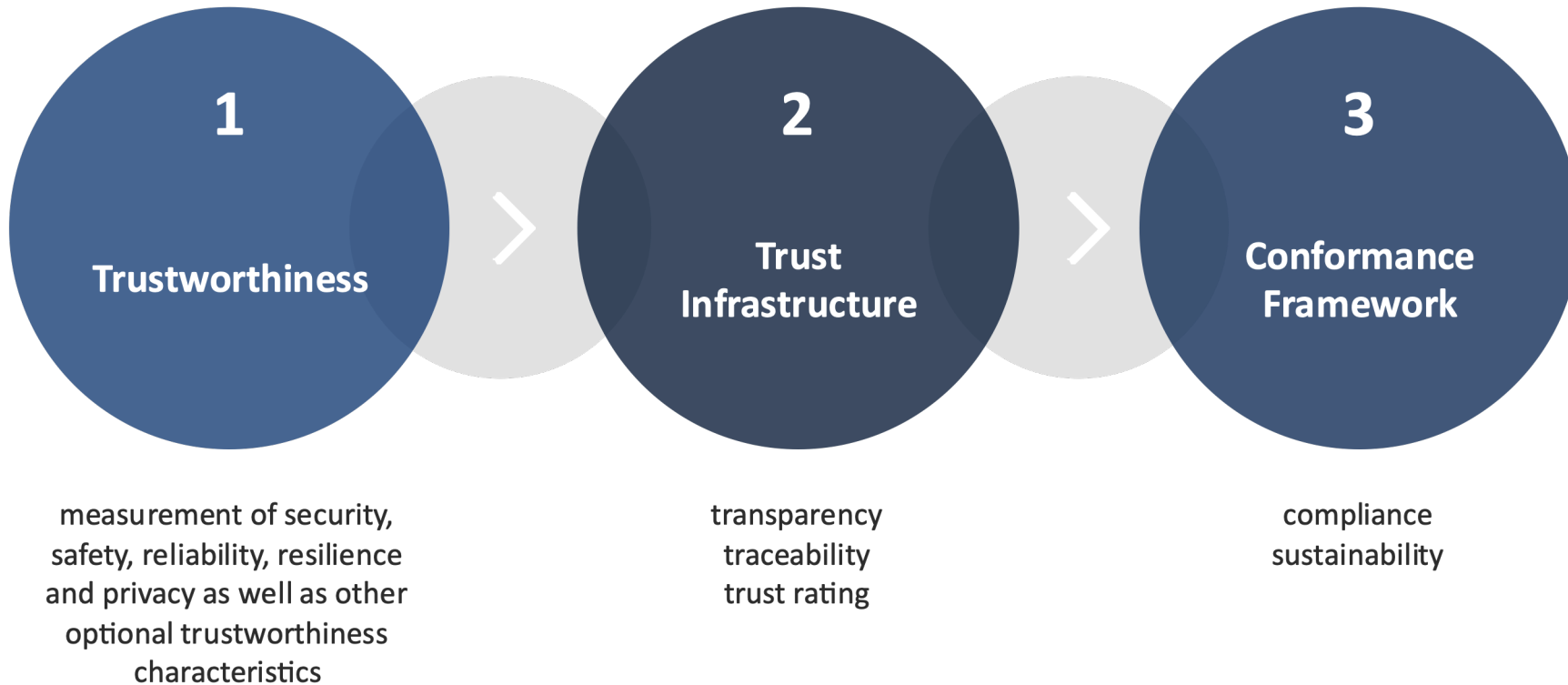



# Principle 10

---

A trustworthiness framework must enable timely business decisions to gain confidence that the system performs as expected.

- transparent and traceable
- measuring trustworthiness must be rigorous, pragmatic, and address operating concerns
- make decisions in a timely manner
- intuitive and actionable so that organizations

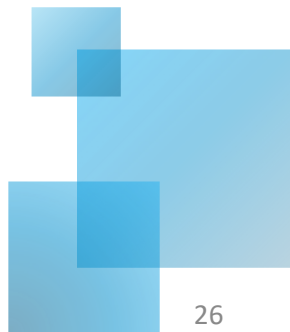

# Principle 11

Assurance requires a systems viewpoint with evidence of multiple factors.

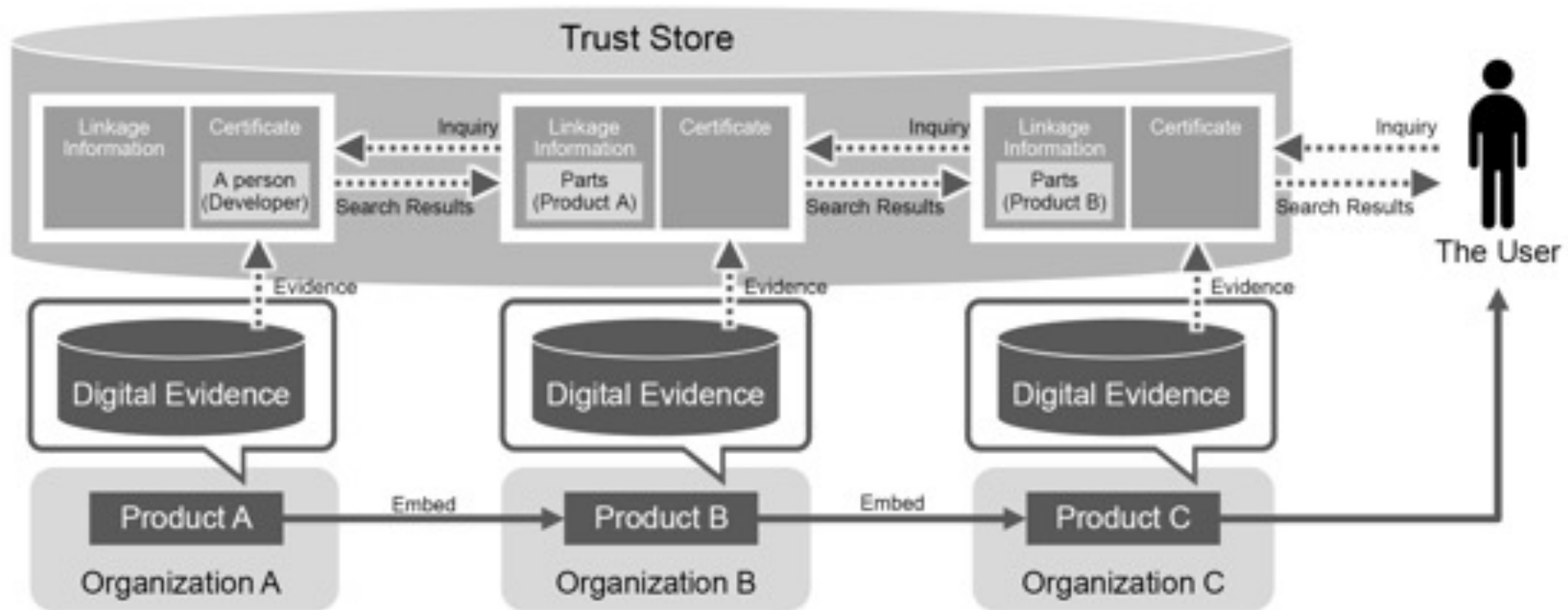

# You can't live without trustworthiness!

---

- Principle 1: Trustworthiness characteristics must be considered holistically.
- Principle 2: Understanding context is necessary for making Trustworthiness tradeoffs.
- Principle 3: Organizational consistency over time enables reputation and trust.
- Principle 4: Accountability is an essential underlying foundation of trustworthiness.
- Principle 5: A culture of trustworthiness is essential to achieving trustworthiness.
- Principle 6: Assurance based on evidence is essential to establish trustworthiness.
- Principle 7: Software trustworthiness must be managed throughout the entire software lifecycle.
- Principle 8: Implementing trustworthiness means implementing trustworthiness methods
- Principle 9: Maintaining change and audit records is necessary for trustworthiness.
- Principle 10: A trustworthiness framework must enable timely business decisions.
- Principle 11: Assurance requires a systems viewpoint with evidence of multiple factors.

# Questions?

[mellor@omg.org](mailto:mellor@omg.org)

[hub.iiconsortium.org](http://hub.iiconsortium.org)

[www.iiconsortium.org](http://www.iiconsortium.org)

[info@iiconsortium.org](mailto:info@iiconsortium.org)



# Trusted Enterprise



Trustworthiness is difficult enough to establish for a single system.

What about collaborating systems?

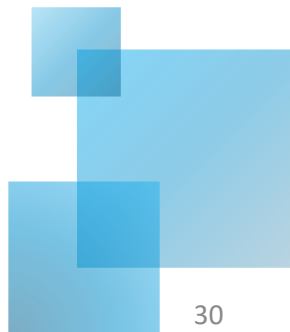

# Trust Vectors (Supplied)

What is the trustworthiness level of another system component?

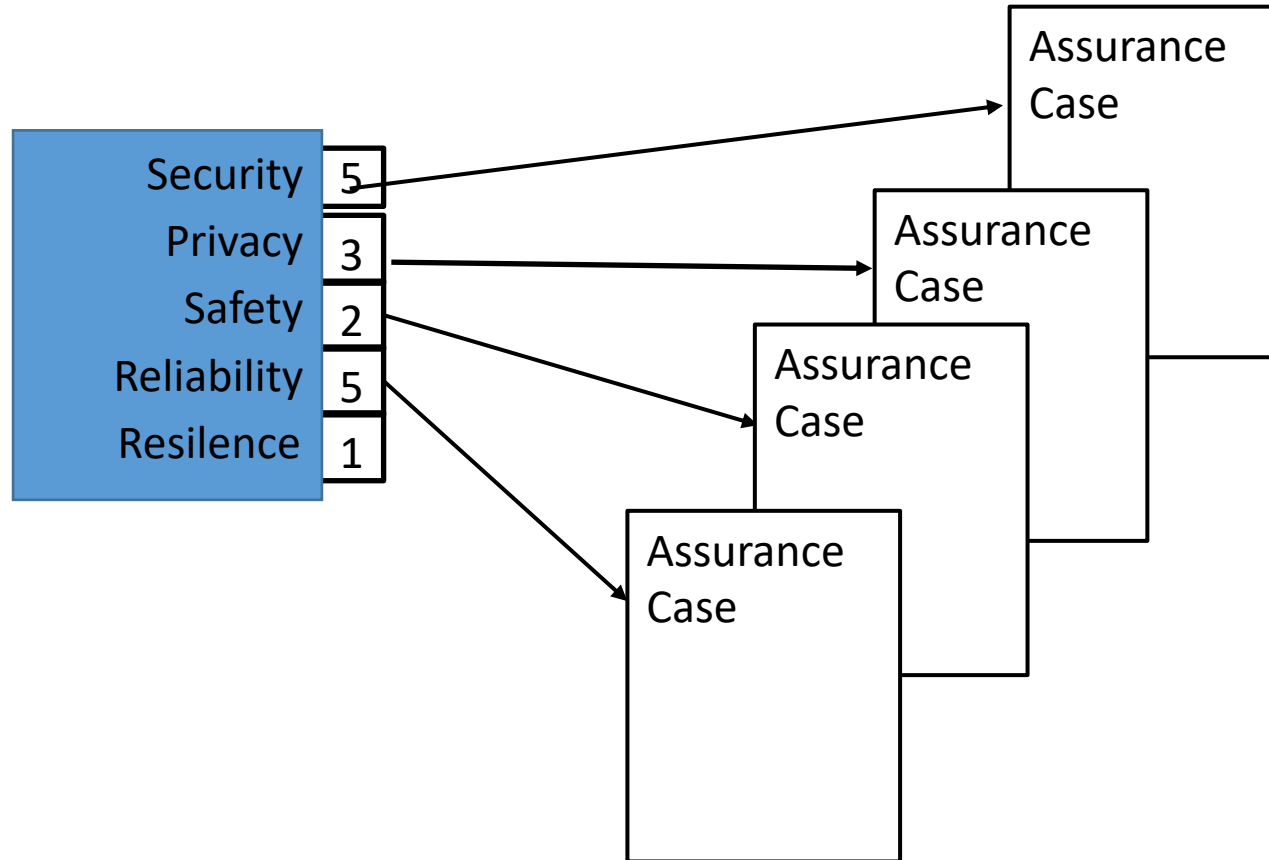



# Trust Vectors (Required)

What level of trustworthiness do I need?

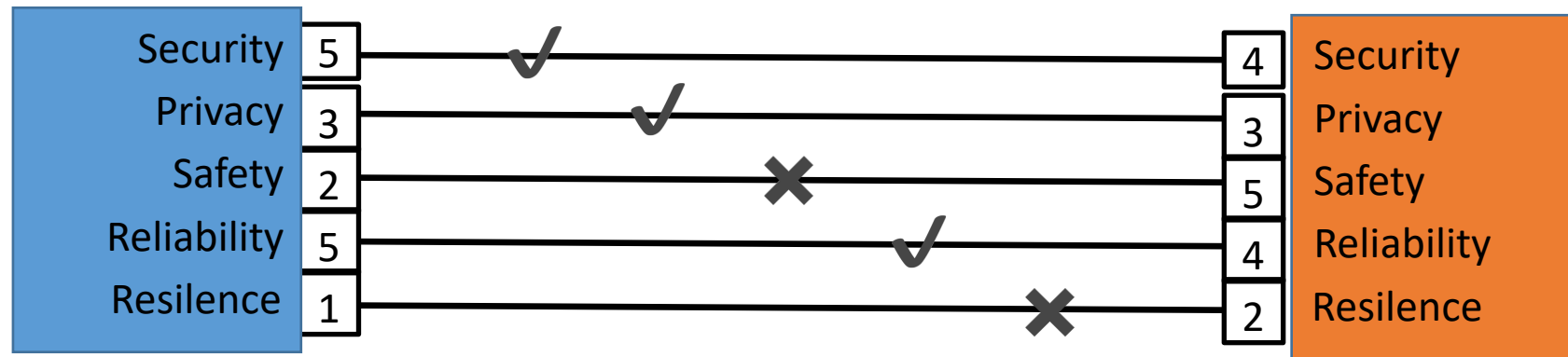



# Questions?

[mellor@omg.org](mailto:mellor@omg.org)

[hub.iiconsortium.org](http://hub.iiconsortium.org)

[www.iiconsortium.org](http://www.iiconsortium.org)

[info@iiconsortium.org](mailto:info@iiconsortium.org)

